



TH	THAILAND
----	----------

Diagram / Parts List

DCU180

BATTERY POWERED WHEELBARROW



(TH) DCU180 / BATTERY POWERED WHEELBARROW

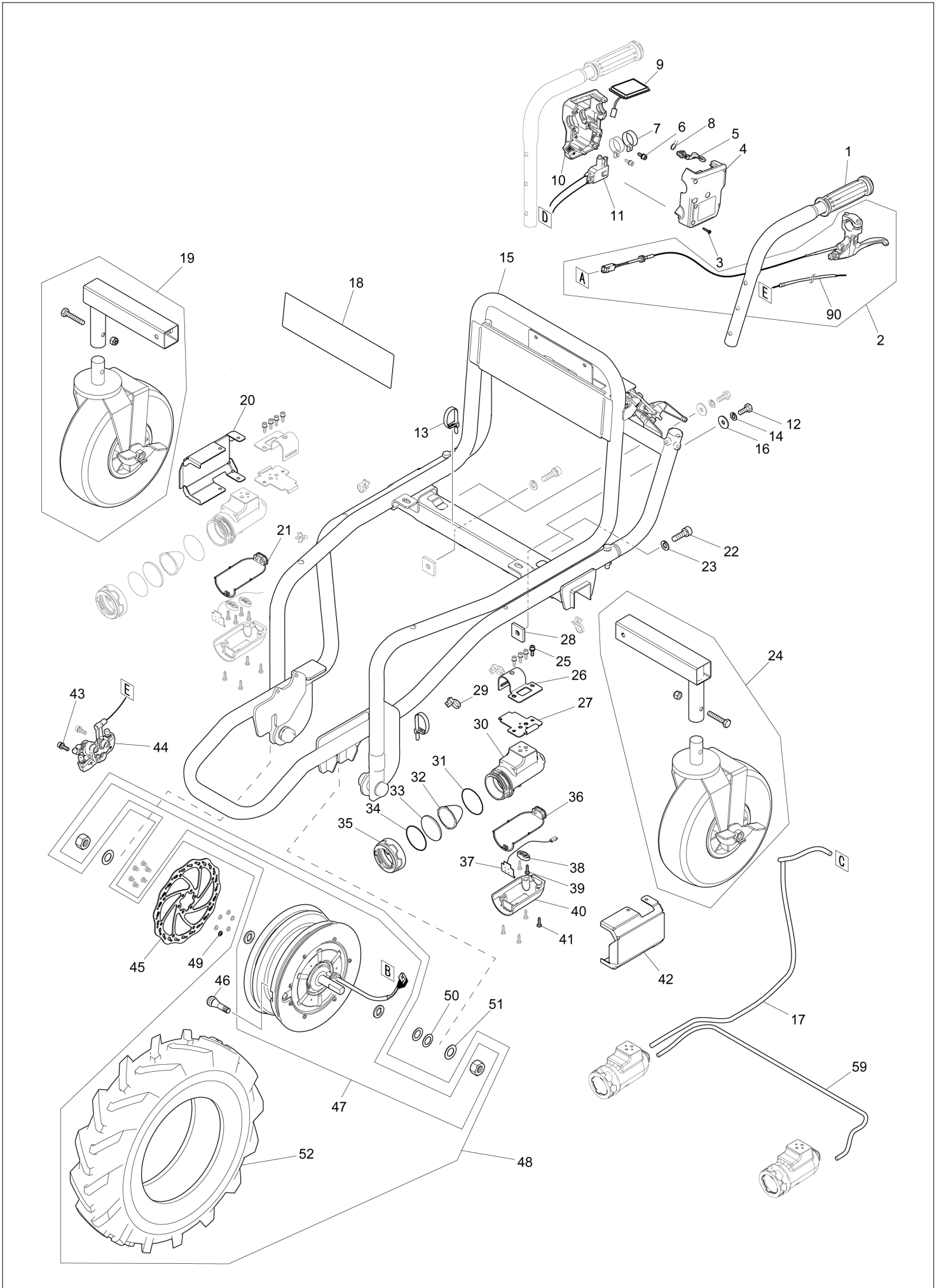

(TH) DCU180 / BATTERY POWERED WHEELBARROW

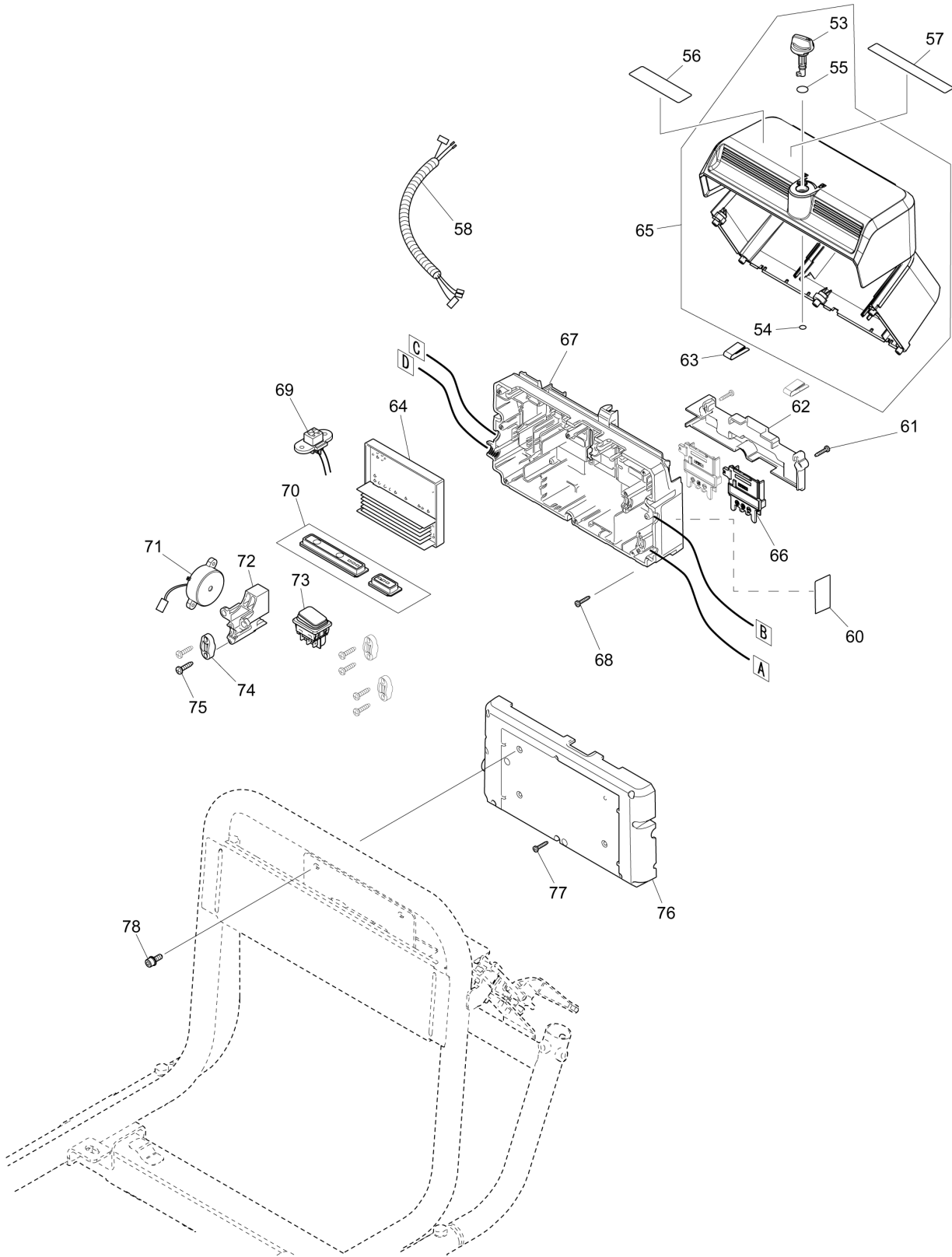

(TH) DCU180 / BATTERY POWERED WHEELBARROW

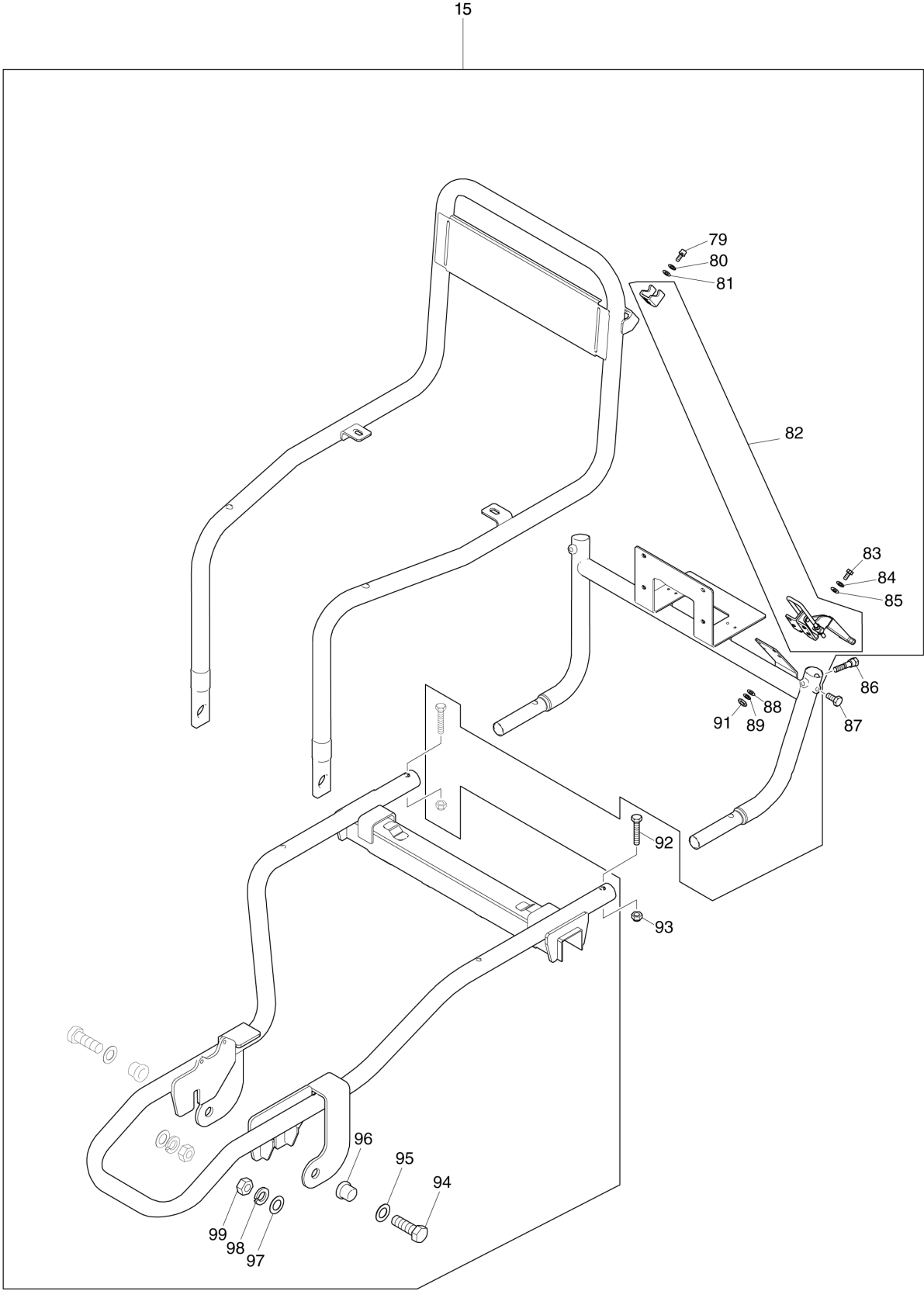

TH	THAILAND
-----------	-----------------

DCU180 / BATTERY POWERED WHEELBARROW

Item	Sub	Parts No.	Parts Description	Qty	I/C	E/C No.	Close No.	Remark
001		161640-0	HANDLE COMPLETE	2				
002		161648-4	BRAKE ASSEMBLY	1				
	D10		INC. 90					
003		266130-9	TAPPING SCREW BIND PT 3X16	5				
004		183H15-1	SWITCH BOX SET	1			C2773	
	C10	813J54-6	CAUTION LABEL	1			C2773	
	D10		INC. 10				C2773	
004-1		183H15-1	SWITCH BOX SET	1	<	C2773		
	C10	813J54-6	CAUTION LABEL	1		C2773		
	D10		INC. 10			C2773		
005		457633-6	SWITCH LEVER	1				
006		922223-9	H.S.H.BOLT M5X16 WITH WR	2			D0120	
006-1		265A97-4	H.S.H.BOLT M5X16 WITH WR	2	<	D0120		
007		346249-1	PIPE CLAMP 28	2				
008		233540-5	TORSION SPRING 11	1				
009		144521-3	SWITCH PLATE COMPLETE	1				
	C10	812S78-3	SWITCH LABEL	1				
010		183H15-1	SWITCH BOX SET	1			C2773	
	C10	813J54-6	CAUTION LABEL	1			C2773	
	D10		INC. 4				C2773	
010-1		183H15-1	SWITCH BOX SET	1	<	C2773		
	C10	813J54-6	CAUTION LABEL	1		C2773		
	D10		INC. 4			C2773		
011		650781-2	SWITCH C3JW-6B-P	1				
012		251595-8	HEX.BOLT M8X20	2				
013		687410-4	BAND	2				
014		942201-3	SPRING WASHER 8	2				
015		126589-1	FRAME ASSEMBLY	1			C2897	
	D10		INC. 79-89,91-99				C2897	
015-1		126905-7	FRAME ASSEMBLY	1	S	C2897		
	D10		INC. 79-89,91-99			C2897	Y07950	
	D11		INC. 79-85,88,89,91,94-99			Y07950		
016		253852-0	FLAT WASHER 8	2				
017		699095-4	POWER SUPPLY CORD UNIT	1				
018		812S79-1	MAKITA LOGO LABEL	1				
019		126893-8	REAR TIRE R ASSEMBLY	1			C3920	
	C10	161639-5	JOINT	1			C3920	
	C20	161868-0	TIRE 260 WITH STOPPER	1			C3920	
	C30	921467-8	HEX. BOLT M8X45	1			C3920	
	C40	252105-4	HEX. LOCK NUT M8-13	1			C3920	
019-1		127092-5	REARTIRE ASSEMBLY WITH STOPPER	1	O	C3920	DA717	
	C10	161836-3	JOINT	1		C3920	DA717	
	C20	161868-0	TIRE 260 WITH STOPPER	1		C3920	DA717	
	C30	921467-8	HEX. BOLT M8X45	1		C3920	DA717	
	C40	252105-4	HEX. LOCK NUT M8-13	1		C3920	DA717	
019-2		127092-5	REARTIRE ASSEMBLY WITH STOPPER	1	O	DA717		
	C10	161836-3	JOINT	1		DA717		
	C20	161868-0	TIRE 260 WITH STOPPER	1		DA717		
	C30	921467-8	HEX. BOLT M8X45	1		DA717		
	C40	252105-4	HEX. LOCK NUT M8-13	1		DA717		
020		347278-7	GUARD R	1				
021		422151-3	PACKING	1				
022		266240-2	HEX. SOCKET HEAD BOLT M10X25	2			C2897	
023		941251-5	FLAT WASHER 10	2			C2897	
024		126837-8	REAR TIRE L ASSEMBLY	1			C3920	
	C10	161663-8	JOINT L	1			C3920	
	C20	161868-0	TIRE 260 WITH STOPPER	1			C3920	
	C30	921467-8	HEX. BOLT M8X45	1			C3920	
	C40	252105-4	HEX. LOCK NUT M8-13	1			C3920	
024-1		127092-5	REARTIRE ASSEMBLY WITH STOPPER	1	O	C3920	DA717	
	C10	161836-3	JOINT	1		C3920	DA717	
	C20	161868-0	TIRE 260 WITH STOPPER	1		C3920	DA717	
	C30	921467-8	HEX. BOLT M8X45	1		C3920	DA717	
	C40	252105-4	HEX. LOCK NUT M8-13	1		C3920	DA717	
024-2		127092-5	REARTIRE ASSEMBLY WITH STOPPER	1	O	DA717		

A:DCU180Z(N)

Interchange
 O : Yes
 X : No
 < : the new part can be substituted for the current.
 > : the current part can be substituted for the new.
 S : Interchangeable as a set.

TH	THAILAND
----	----------

DCU180 / BATTERY POWERED WHEELBARROW

Item	Sub	Parts No.	Parts Description	Qty	I/C	E/C No.	Close No.	Remark
	C10	161836-3	JOINT	1		DA717		
	C20	161868-0	TIRE 260 WITH STOPPER	1		DA717		
	C30	921467-8	HEX. BOLT M8X45	1		DA717		
	C40	252105-4	HEX. LOCK NUT M8-13	1		DA717		
025		922223-9	H.S.H.BOLT M5X16 WITH WR	8			D0120	
025-1		265A97-4	H.S.H.BOLT M5X16 WITH WR	8	<	D0120		
026		347238-9	CLAMP A	2				
027		347239-7	CLAMP B	2				
028		347394-5	PLATE	2			C2897	
029		687849-1	BAND	5				
030		319594-7	LIGHT CASE	2				
031		213656-2	O RING 53	2				
032		457636-0	REFLECTOR	2				
033		457634-4	LENS	2				
034		213604-1	O RING 50	2				
035		457635-2	COVER	2				
036		422166-0	PACKING	1				
037		620685-2	LED CIRCUIT	2				
038		687123-7	STRAIN RELIEF	3				
039		266034-5	TAPPING SCREW CT 4X16	6				
040		319595-5	LIGHT CASE COVER	2				
041		266034-5	TAPPING SCREW CT 4X16	8				
042		347279-5	GUARD L	1				
043		922328-5	H.S.H.BOLT M6X18 WITH WR	2			D0120	
043-1		265A98-2	H.S.H.BOLT M6X18 WITH WR	2	<	D0120		
044		161641-8	BRAKE CALIPER ASSEMBLY	1				
045		347208-8	BRAKE DISC	1				
046		161638-7	SNAP IN VALVE	1				
047		126590-6	WHEEL	1			B9602	
	C10	BF00000002	HEX. NUT M16	2			B9602	
	C20	BF00000003	FLAT WASHER	2			B9602	
	C30	BF00000001	HEX. SOCKET BUTTON BOLT M5X8	6			B9602	
047-1		126590-6	WHEEL	1	S	B9602	C2897	
	C10	BF00000002	HEX. NUT M16	2		B9602	C2897	
	C20	BF00000003	FLAT WASHER	2		B9602	C2897	
	C30	BF00000001	HEX. SOCKET BUTTON BOLT M5X8	6		B9602	C2897	
047-2		126904-9	WHEEL	1	S	C2897		
	C10	BF00000002	HEX. NUT M16	2		C2897		
	C20	BF00000003	FLAT WASHER	2		C2897		
	C30	BF00000001	HEX. SOCKET BUTTON BOLT M5X8	6		C2897		
048		126734-8	FRONT TIRE ASSEMBLY	1			C2897	
	D10		INC. 46,47,52				C2897	
048-1		127081-0	FRONT TIRE ASSEMBLY	1	S	C2897		
	D10		INC. 46,47,52			C2897		
049		941102-2	FLAT WASHER 5	6			B9602	
050		232247-0	CONED DISC SPRING 16	2			D0120	
050-1		232605-0	CONED DISC SPRING 16	2	<	D0120		
051		253377-4	FLAT WASHER 17	2			D0120	
051-1		253470-4	FLAT WASHER 17	2	<	D0120		
052		422159-7	FRONT TIRE 430	1				
053		457625-5	LEVER 25	1				
054		213005-3	O RING 5	1				
055		213078-6	O-RING 10	1				
056		816M70-5	INDICATION LABEL	1				
057		816N32-9	CAUTION LABEL	1				
058		632K49-4	LEAD UNIT	1				
059		699096-2	POWER SUPPLY CORD UNIT	1				
	C10	682576-5	GROMMET	1				
	C20	688162-0	LINE FILTER	2				
060		853S84-9	DCU180 NAME PLATE	1				
061		266130-9	TAPPING SCREW BIND PT 3X16	2				
062		457629-7	TERMINAL HOLDER	1				
063		232267-4	LEAF SPRING	2				
064		620675-5	CONTROLLER	1			DL351	
064-1		620M45-6	CONTROLLER	1	<	DL351		

A:DCU180Z(N)

Interchange
 O : Yes
 X : No
 < : the new part can be substituted for the current.
 > : the current part can be substituted for the new.
 S : Interchangeable as a set.

DCU180 / BATTERY POWERED WHEELBARROW

Item	Sub	Parts No.	Parts Description	Qty	I/C	E/C No.	Close No.	Remark
065		135934-9	BATTERY BOX ASSY	1				
	D10		INC. 53-55					
066		643874-2	TERMINAL	2				
067		144519-0	CENTER CASE COMPLETE	1				
	C10	263005-3	RUBBER PIN 6	4				
068		266130-9	TAPPING SCREW BIND PT 3X16	5				
069		632K50-9	LEAD UNIT	1				
070		144520-5	SUB CONTROLLER COMPLETE	1				
071		620684-4	BUZZER CIRCUIT	1				
072		457630-2	COVER	1				
073		651534-2	SWITCH 1934.3112B	1				
074		687123-7	STRAIN RELIEF	3				
075		266326-2	TAPPING SCREW 4X18	6				
076		457628-9	FRONT COVER	1				
077		266130-9	TAPPING SCREW BIND PT 3X16	8				
078		922218-2	H.S.H.BOLT M5X14 WITH WR	4			D0120	
078-1		265A96-6	H.S.H.BOLT M5X14 WITH WR	4	<	D0120		
079		TR00000069	HEX.SOCKET HEAD BOLT M5X14	2				
080		942101-7	SPRING WASHER 5	2				
081		941101-4	FLAT WASHER 5	2				
082		TR00000067	LOCK LEVER	1				
083		TR00000068	HEX.BOLT M5X16	4				
084		942101-7	SPRING WASHER 5	4				
085		941101-4	FLAT WASHER 5	4				
086		251594-0	SHOULDER HEX. BOLT M8X40	2				
087		251595-8	HEX.BOLT M8X20	2				
088		941101-4	FLAT WASHER 5	4				
089		942101-7	SPRING WASHER 5	4				
090		144700-3	BRAKE CABLE	1				
091		931202-6	HEX. NUT M5	4				
092		921467-8	HEX. BOLT M8X45	2				
093		252105-4	HEX. LOCK NUT M8-13	2				
094		TR00000070	HEX.BOLT M16X50	2				
095		TR00000073	FLAT WASHER 17	2				
096		326968-5	SLEEVE 17	2				
097		TR00000073	FLAT WASHER 17	2				
098		TR00000072	SPRING 16	2				
099		TR00000071	HEX.NUT M16-24	2				
100		941102-2	FLAT WASHER 5	6	S	C2897		
101		253377-4	FLAT WASHER 17	1	S	C2897		
A01		144675-6	FOOT COMPLETE	2				
A02		455588-9	WIRE CLAMP	2				
A03		643890-4	KEY	1				
A04		781006-4	WRENCH 13	2				
F01		198494-2	BUCKET SET	1				
F04		199116-7	CARRIER SET	1				
F05		191A01-6	AUXILIARY WHEEL ATTACHMENT SET	1		C7323		

A:DCU180Z(N)

Interchange
 O : Yes
 X : No
 < : the new part can be substituted for the current.
 > : the current part can be substituted for the new.
 S : Interchangeable as a set.