

Diagram / Parts List

DUP361

BATTERY POWERED PRUNING SHEAR



(TH) DUP361 / BATTERY POWERED PRUNING SHEAR

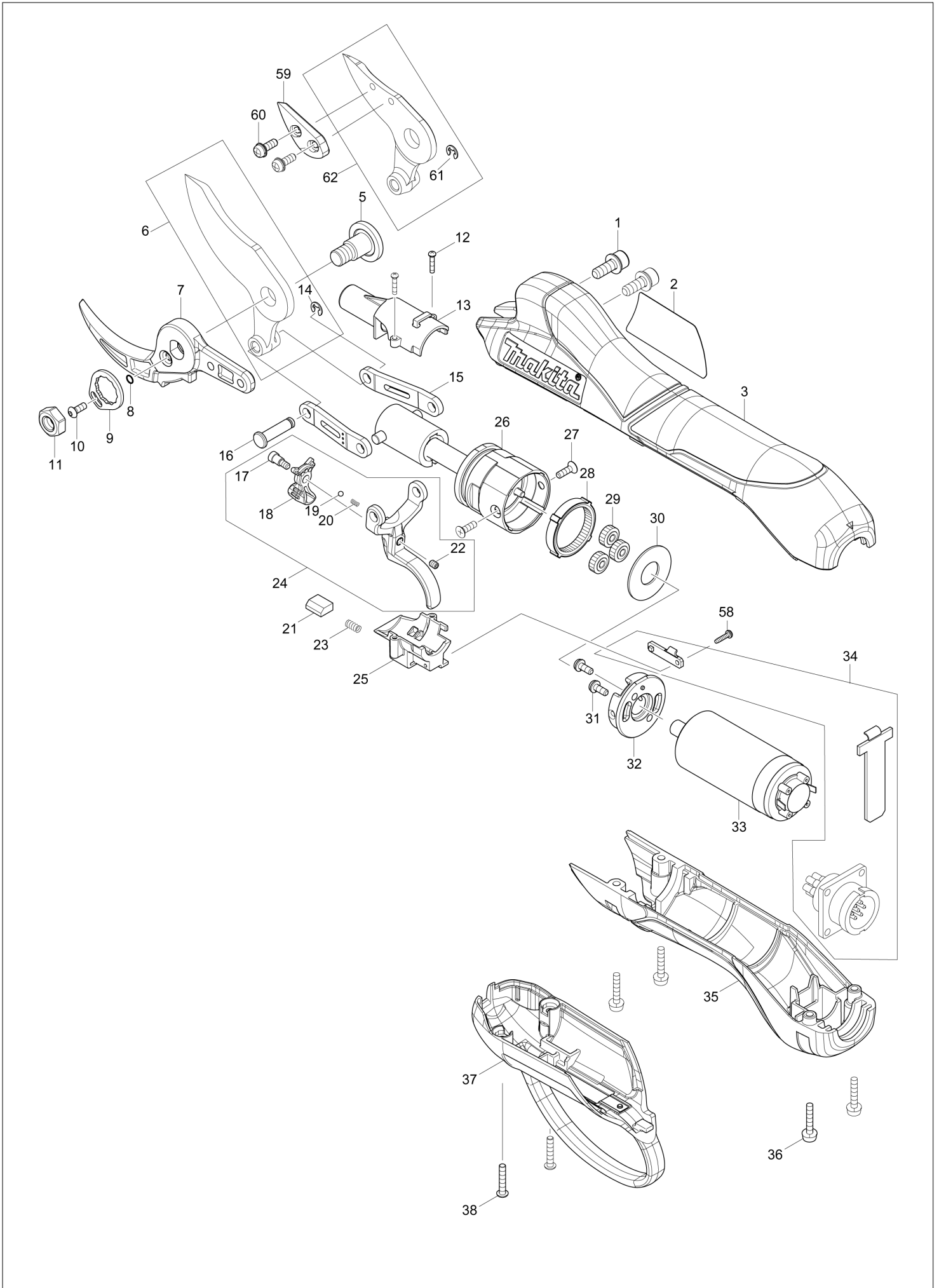

(TH) DUP361 / BATTERY POWERED PRUNING SHEAR

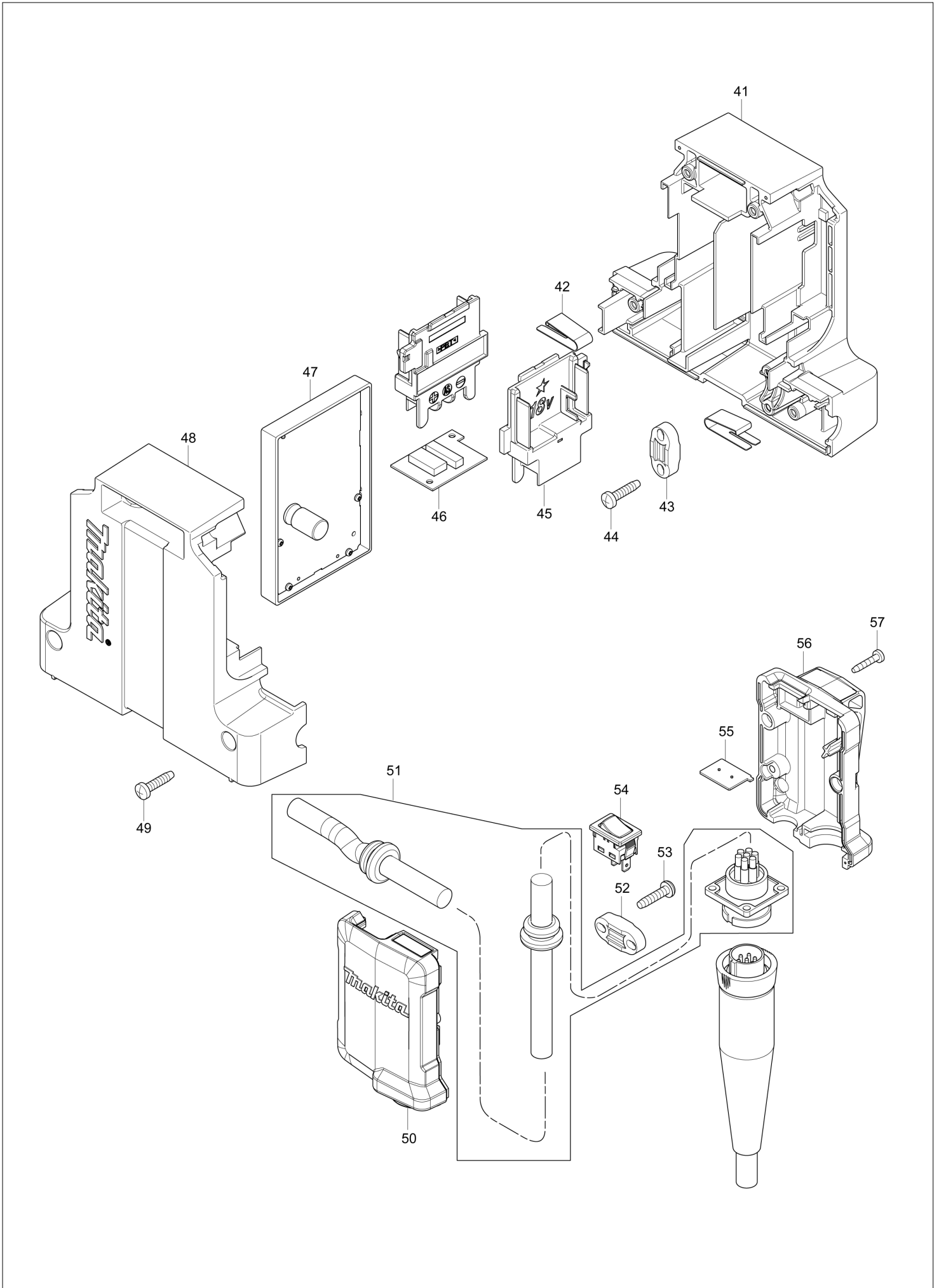

TH	THAILAND
-----------	-----------------

DUP361 / BATTERY POWERED PRUNING SHEAR

Item	Sub	Parts No.	Parts Description	Qty	I/C	E/C No.	Close No.	Remark
001A		251485-5	H.S.H.BOLT M5X14 WITH WR	2			B1212	
001B		251485-5	H.S.H.BOLT M5X14 WITH WR	2			B1212	
001-1A		251490-2	H.S.H.BOLT M5X14 WITH WR	2	<	B1212		
001-1B		251490-2	H.S.H.BOLT M5X14 WITH WR	2	<	B1212		
001-1C		251490-2	H.S.H.BOLT M5X14 WITH WR	2				
001-1D		251490-2	H.S.H.BOLT M5X14 WITH WR	2				
002		851F32-4	DUP361 NAME PLATE	1				
003		456209-6	UPPER HOUSING	1				
005		251474-0	SHOULDER SCREW M8	1				
006		197366-8	SHEAR BLADE U SET	1				
	D10		INC. 14					
007		197367-6	SHEAR BLADE L SET(EU)	1			Y07644	
007-1		197749-2	SHEAR BLADE L SET	1	O	Y07644		
008		213034-6	O RING 3	1				
009		346940-1	LOCK PLATE	1				
010		266557-3	H.S.BUTTON HEAD BOLT M3X8	1				
011		264118-3	HEX. NUT M8	1				
012		266786-8	+ PAN HEAD TAPPING SCREW 2X10	2				
013		456218-5	BALL NUT COVER B	1				
014		961011-9	STOP RING E-4	1				
015A		346941-9	LINK ARM	2			B6023	
015B		346941-9	LINK ARM	2			B6023	
015-1A		347165-0	LINK ARM	2	<	B6023		
015-1B		347165-0	LINK ARM	2	<	B6023		
015-1C		347165-0	LINK ARM	2				
015-1D		347165-0	LINK ARM	2				
016		256568-6	FLAT FILLISTER HD.PIN 5	1				
017		251484-7	+ FLAT HEAD SCREW M3X4	1				
018		456215-1	LEVER	1				
019		216031-1	STEEL BALL 2.3	1				
020		233491-2	COMPRESSION SPRING 2	1				
021		688189-0	MAGNET	1				
022		266999-1	H.S.SET SCREW(FLAT POINT)M3X4	1				
023		231397-8	COMPRESSION SPRING 4	1				
024		123536-3	TRIGGER ASS'Y	1				
	D10		INC. 17-20,22					
025		456217-7	BALL NUT COVER A	1				
026		123458-7	BALL SCREW ASSEMBLY	1			C8740	
026-1		127418-1	BALL SCREW ASSEMBLY	1	<	C8740		
027		912012-0	C.H.SCREW M3X10	2				
028		227390-8	INTERNAL GEAR 48	1				
029		227389-3	SPUR GEAR 18	3				
030		253810-6	FLAT WASHER 12	1				
031		911006-2	PAN HEAD SCREW M3X8	2				
032		319349-0	MOTOR HOLDER	1				
033		629160-5	DC MOTOR	1				
034		620459-1	SUB CONTROLLER	1				
035		456211-9	LOWER HOUSING	1				
036		911028-2	PAN HEAD SCREW M3X16	4				
037A		143633-9	FRONT HOUSING COMPLETE	1			B1212	
	C10	807L80-7	INDICATION LABEL	1			B1212	
037B		143633-9	FRONT HOUSING COMPLETE	1			B1212	
	C10	807L80-7	INDICATION LABEL	1			B1212	
037-1A		143935-3	FRONT HOUSING COMPLETE	1	<	B1212		
	C10	807L80-7	INDICATION LABEL	1		B1212		
037-1B		143935-3	FRONT HOUSING COMPLETE	1	<	B1212		
	C10	807L80-7	INDICATION LABEL	1		B1212		
037-1C		143935-3	FRONT HOUSING COMPLETE	1				
	C10	807L80-7	INDICATION LABEL	1				
037-1D		143935-3	FRONT HOUSING COMPLETE	1				
	C10	807L80-7	INDICATION LABEL	1				
038		266980-2	HEX.S.BUTTON HEAD SCREW M3X16	2				
041		183B69-2	CONTROLLER HOUSING SET	1				
	D10		INC. 48					
042		232267-4	LEAF SPRING	2				

A:DUP361RM2(H)
 B:DUP361Z(N)
 C:DUP361RM2N(H)
 D:DUP361Z(N)

Interchange
 O : Yes
 X : No
 < : the new part can be substituted for the current.
 > : the current part can be substituted for the new.
 S : Interchangeable as a set.

TH	THAILAND
-----------	-----------------

DUP361 / BATTERY POWERED PRUNING SHEAR

Item	Sub	Parts No.	Parts Description	Qty	I/C	E/C No.	Close No.	Remark
043		687053-2	STRAIN RELIEF	1				
044		265995-6	TAPPING SCREW 4X18	2				
045		643899-6	TERMINAL	2				
046		620461-4	RF UNIT	1				
047		620458-3	CONTROLLER	1				
048		183B69-2	CONTROLLER HOUSING SET	1				
	D10		INC. 41					
049		265995-6	TAPPING SCREW 4X18	4				
050		183B76-5	SWITCH HOUSING SET	1				
	C10	807E89-7	INDICATION LABEL	1				
	C20	807F74-6	CAUTION LABEL	1				
	D10		INC. 56					
051A		699070-0	POWER SUPPLY CORD UNIT	1			B4893	
051B		699070-0	POWER SUPPLY CORD UNIT	1			B4893	
051-1A		699086-5	POWER SUPPLY CORD UNIT	1	<	B4893		
051-1B		699086-5	POWER SUPPLY CORD UNIT	1	<	B4893		
051-1C		699086-5	POWER SUPPLY CORD UNIT	1				
051-1D		699086-5	POWER SUPPLY CORD UNIT	1				
052		687053-2	STRAIN RELIEF	1				
053		265995-6	TAPPING SCREW 4X18	2				
054		651536-8	SWITCH 1941. 1451	1				
055		620460-6	LED CIRCUIT	1				
056		183B76-5	SWITCH HOUSING SET	1				
	C10	807E89-7	INDICATION LABEL	1				
	C20	807F74-6	CAUTION LABEL	1				
	D10		INC. 50					
057		266429-2	TAPPING SCREW 3X16	3			DE715	
057-1		266130-9	TAPPING SCREW BIND PT 3X16	3	O	DE715		
058		266786-8	+ PAN HEAD TAPPING SCREW 2X10	1				
A01		154511-8	CORD HOLDER COMPLETE	1				
A02A		161377-9	HARNESS	1				
A02B		161377-9	HARNESS	1				
A02C		161603-6	HARNESS	1				
A02D		161603-6	HARNESS	1				
A03		161379-5	HOLSTER	1				
A04		166062-9	ARM BAND	1				
A05		182470-6	OIL SUPPLY	1				
A06A		661430-6	CONNECTION CORD	1			B3728	
A06B		661430-6	CONNECTION CORD	1			B3728	
A06-1A		661445-3	CONNECTION CORD	1	<	B3728		
A06-1B		661445-3	CONNECTION CORD	1	<	B3728		
A06-1C		661445-3	CONNECTION CORD	1				
A06-1D		661445-3	CONNECTION CORD	1				
A07		794530-8	DIAMOND FILE 140	1				
A08		782212-4	SOCKET WRENCH 13	1				
A09		783021-4	HEX. WRENCH 1.5	1				
A10		783202-0	HEX. WRENCH 4	1				
A11		783214-3	HEX.SOCKET SCREW KEY 2	1				
A12		831284-7	TOOL BAG	1				
A13		197366-8	SHEAR BLADE U SET	1				
	C10	961011-9	STOP RING E-4	1				
A14A		***DC18RC	DC18RC FAST CHARGER	1				
A14C		***DC18RC	DC18RC FAST CHARGER	1				
A15A		197265-4	BATTERY BL1840B SET	2			C5218	
A15C		197265-4	BATTERY BL1840B SET	2			C5218	
A15-1A		197265-4	BATTERY BL1840B SET	2	O	C5218		
A15-1C		197265-4	BATTERY BL1840B SET	2	O	C5218		
A16A		450128-8	BATTERY COVER	2				
A16C		450128-8	BATTERY COVER	2				
A17A		630999-1	CONTROLLER	1		Y07472	Y07816	
A17B		630999-1	CONTROLLER	1		Y07472	Y07816	
A17C		630999-1	CONTROLLER	1			Y07816	
A17D		630999-1	CONTROLLER	1			Y07816	
B01		630999-1	CONTROLLER	1		Y07816		
	D10		INC. 41-57			Y07816		

A:DUP361RM2(H)
 B:DUP361Z(N)
 C:DUP361RM2N(H)
 D:DUP361Z(N)

Interchange
 O : Yes
 X : No
 < : the new part can be substituted for the current.
 > : the current part can be substituted for the new.
 S : Interchangeable as a set.

