



TH	THAILAND
----	----------

Diagram / Parts List

VC011G

DC BACKPACK VACUUM CLEANER



(TH) VC011G / DC BACKPACK VACUUM CLEANER

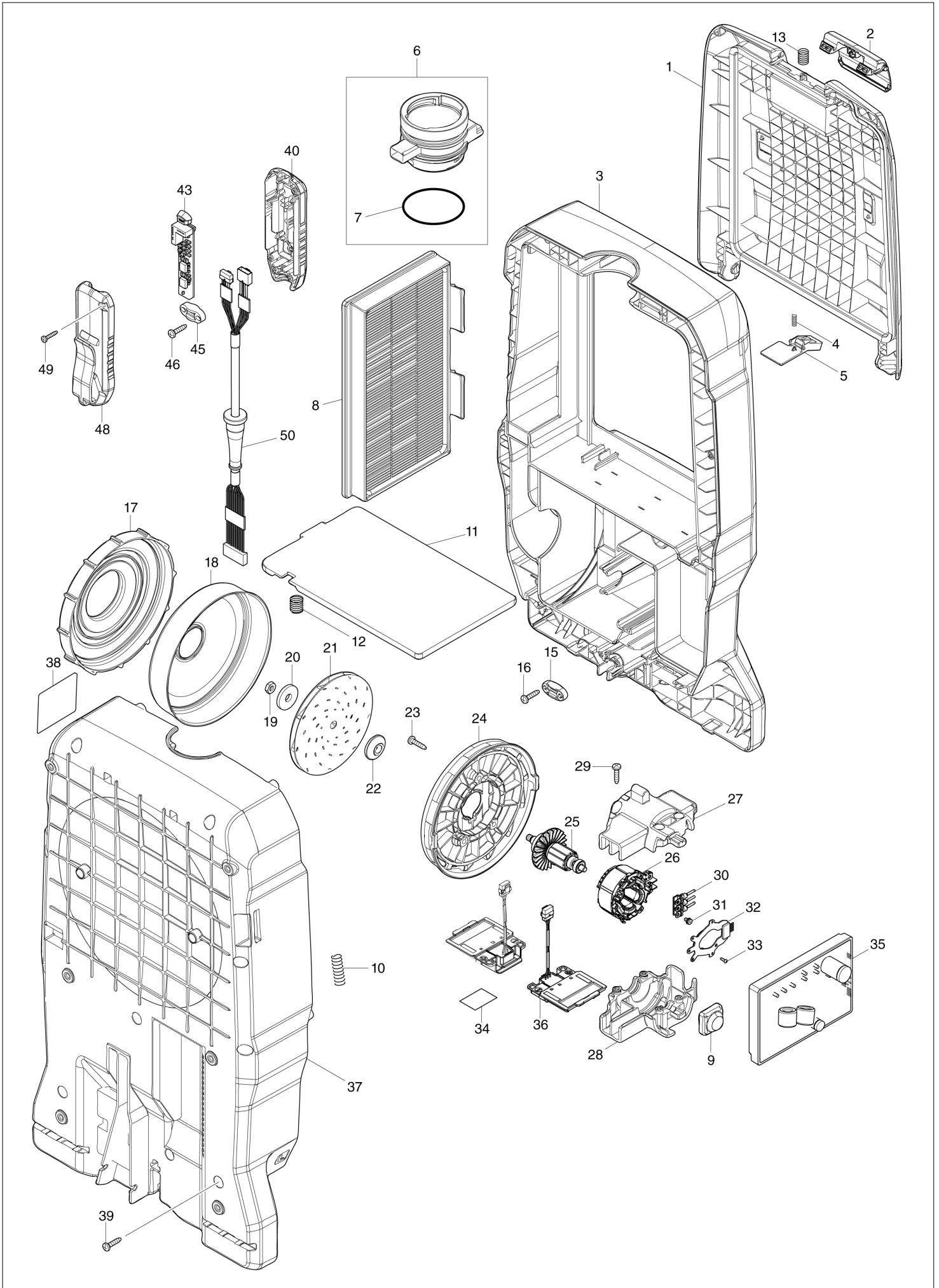

(TH) VC011G / DC BACKPACK VACUUM CLEANER

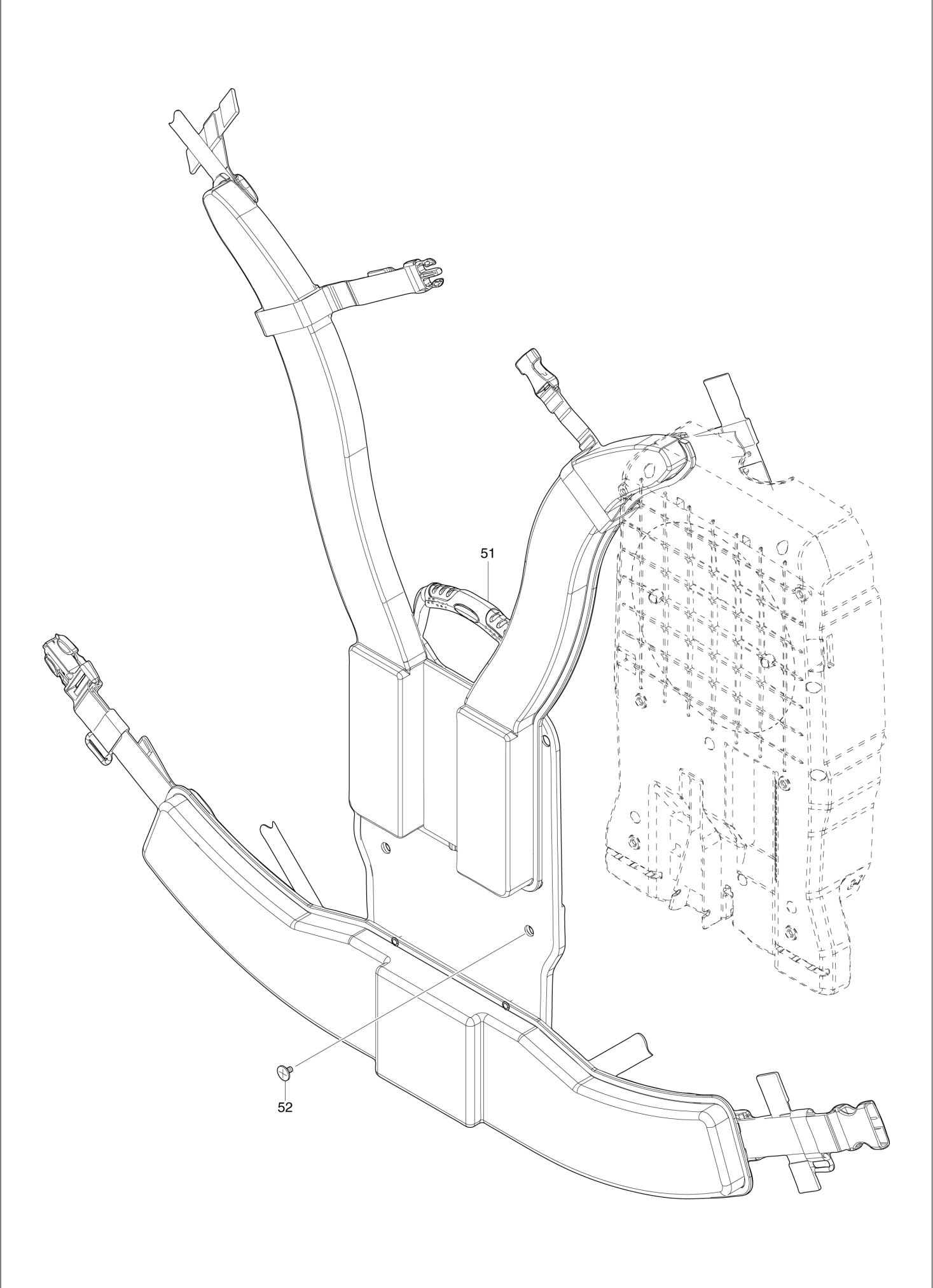

TH	THAILAND
----	----------

VC011G / DC BACKPACK VACUUM CLEANER

Item	Sub	Parts No.	Parts Description	Qty	I/C	E/C No.	Close No.	Remark
001		141S81-0	DUST BOX COVER COMPLETE	1				
	C10	422A82-2	SEAL A	1				
002		413E52-6	HOOK	1				
003		137050-3	UPPER HOUSING ASSEMBLY	1				
	C10	263005-3	RUBBER PIN 6	2				
	C20	422A76-7	REAR BLOCK FILTER	1				
004		232389-0	COMPRESSION SPRING 5	1				
005		459912-8	STOPPER PLATE	1				
006		135771-1	INLET ASS'Y	1				
	D10		INC. 7					
007		213655-4	O RING 56	1				
008		191D12-9	MAIN FILTER H SET	1				
009		422A84-8	SUPPORT A	1				
010		231297-2	COMPRESSION SPRING 9	1				
011		459913-6	PLATE	1				
012		234141-2	COMPRESSION SPRING 12	2				
013		234391-9	COMPRESSION SPRING 8	1				
015		687124-5	STRAIN RELIEF	1				
016		266326-2	TAPPING SCREW 4X18	2				
017		422A83-0	SUPPORT RING	1				
018		347B87-6	FAN COVER	1				
019		252268-6	HEX. NUT M6	1				
020		253752-4	FLAT WASHER 8	1				
021		240178-9	FAN 104	1				
022		313062-2	FLANGE	1				
023		266326-2	TAPPING SCREW 4X18	3				
024		413U78-4	FAN BASE	1				
025		619835-4	ROTOR	1				
026		629C56-8	STATOR	1				
027		1830C1-5	MOTOR HOUSING SET	1				
	D10		INC. 28					
028		1830C1-5	MOTOR HOUSING SET	1				
	D10		INC. 27					
029		266326-2	TAPPING SCREW 4X18	4				
030		638A29-8	LEAD UNIT	1				
031		652069-6	FLAT HEAD SCREW M3X6	3				
032		620F39-9	CONTROLLER B	1				
033		266490-9	TAPPING SCREW PT 2X6	3				
034		8142Y9-1	VC011G SERIAL NO. LABEL	1				
035		620M49-8	CONTROLLER	1				
036		632P49-4	TERMINAL UNIT	2				
037		137051-1	LOWER HOUSING ASSEMBLY	1				
	C10	263005-3	RUBBER PIN 6	2				
	C20	422A76-7	REAR BLOCK FILTER	1				
038		8142Y7-5	VC011G NAME PLAT	1				
039		266326-2	TAPPING SCREW 4X18	11				
040		1830D0-4	SWITCH CASE SET	1				
	C10	8071N8-7	SWITCH LABEL	1				
	D10		INC. 48					
043		620M47-2	SWITCH CIRCUIT	1				
045		687124-5	STRAIN RELIEF	1				
046		266326-2	TAPPING SCREW 4X18	2				
048		1830D0-4	SWITCH CASE SET	1				
	C10	8071N8-7	SWITCH LABEL	1				
	D10		INC. 40					
049		266130-9	TAPPING SCREW BIND PT 3X16	2				
050		699235-4	POWER SUPPLY CORD UNIT	1				
051		162C94-2	HARNESS	1				
052		265008-3	+ FLAT HEAD SCREW M5	6				
A01		191C30-1	DUST BAG SET	1				
A02		191G86-8	NOZZLE ASSEMBLY SET	1				
A03		199453-9	HOSE COMPLETE 32-1.0 SET	1				
A04		140G19-0	TELESCOPIC PIPE COMPLETE	1				
A05		140G26-3	BENT PIPE COMPLETE	1				
A06		166116-2	HOSE BAND	1				

A:VC011GZ(N)

Interchange
 O : Yes
 X : No
 < : the new part can be substituted for the current.
 > : the current part can be substituted for the new.
 S : Interchangeable as a set.

