



TH	THAILAND
----	----------

Diagram / Parts List

9500NB

DISC GRINDER 100MM



(TH) 9500NB / DISC GRINDER 100MM

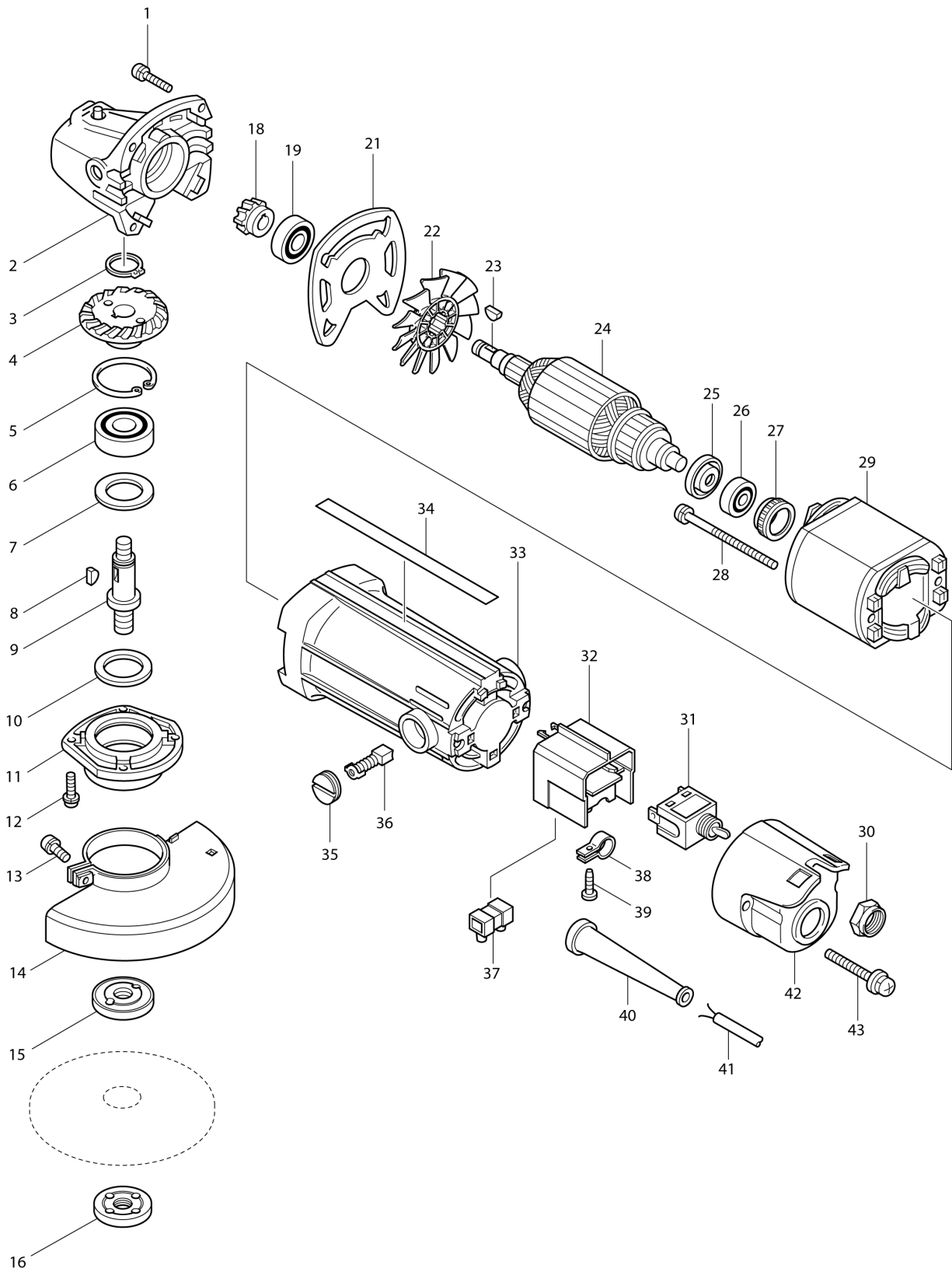

TH	THAILAND
----	----------

9500NB / DISC GRINDER 100MM

Item	Sub	Parts No.	Parts Description	Qty	I/C	E/C No.	Close No.	Remark
001		911136-9	PAN HEAD SCREW M4X20	4				
002		156448-5	GEAR HOUSING	1				
	C10	212005-0	NEEDLE BEARING 810	1				
	C20	231464-9	COMPRESSION SPRING 5	1				
	C30	256616-1	PIN 5	1				
	C40	263002-9	RUBBER PIN 4	1				
	C50	343312-1	CUP	1				
003		961052-5	RETAINING RING (EXT) S-12	1			64546	
004		221319-6	SPIRAL BEVEL GEAR 35	1			64546	
004-1		227424-7	SPIRAL BEVEL GEAR 35	1	X	64546		
005		962151-6	RETAINING RING R-32	1				
006		211106-1	BALL BEARING 6201LLB	1				
007		253055-6	FLAT WASHER 12	1				
008		254002-0	WOODRUFF KEY 3	1			64546	
009-1		324148-7	SPINDLE	1			64546	
009-2		324246-7	SPINDLE	1	>	64546		
010		443034-4	FELT RING 18	1				
011		312998-2	BEARING BOX	1				
012		911121-2	PAN HEAD SCREW M4X14	4				
013		911216-1	PAN HEAD SCREW M5X14	1			73148	
013-1		251391-4	PAN HEAD SCREW M5X16	1	O	73148		
014		133496-1	WHEEL COVER 100	1			73148	
	D10		INC. 13				73148	
014-1		154755-0	WHEEL COVER COMPLETE	1	O	73148		
	D10		INC. 13			73148		
015-1		224314-5	INNER FLANGE 30	1				
016-1		224559-5	LOCK NUT 10-30	1				
018		221318-8	SPIRAL BEVEL GEAR 14	1				
019		211088-7	BALL BEARING 6000DDW	1				
021		341398-9	PLATE	1				
022		240041-6	FAN 60	1				
023		254002-0	WOODRUFF KEY 3	1				
024A		517368-2	ARMATURE ASS'Y 220V	1			Y04069	
	D10		INC. 25,26				Y04069	
024A1		510049-7	ARMATURE ASS'Y 220V	1	<	Y04069		
	D10		INC. 22,25,26			Y04069		
025		681636-0	INSULATION WASHER	1				
026		210017-7	BALL BEARING 607DDW	1				
027		421494-0	RUBBER RING 19	1				
028		911596-5	PAN HEAD SCREW M4X70	2				
029		593479-7	FIELD ASS'Y 240V	1				
	C10	654100-4	RING TERMINAL	2				
	C20	654501-6	CONNECTOR P-1.25	2				
030		652102-4	HEX. NUT M12	1				
031		651403-7	SWITCH ST115A-31	1			85338	
031-1		651433-8	SWITCH ST115A-31	1	<	85338	DB412	
031-2		651433-8	SWITCH ST115A-31	1	O	DB412		
032		687116-4	SUPPORT	1				
033		152675-2	MOTOR HOUSING COMPLETE	1				
	C10	643932-4	BRUSH HOLDER 6X9	2				
034		852662-8	NAME PLATE 9500NB	1				
035		643550-8	BRUSH HOLDER CAP 5-8	2				
036		A-81262	CARBON BRUSH CB-411A	1			65036	
036-1		A-88537	CARBON BRUSH CB-411A	1	<	65036	83185	
036-2		B-80167	CARBON BRUSH SET CB-411A	1	O	83185	85070	
036-3		B-80391	CARBON BRUSH SET CB-411A	1	<	85070		
037		654532-5	TERMINAL BLOCK 1P	1				
038-1		687650-4	STRAIN RELIEF	1				
039		266192-7	TAPPING SCREW 4X14	1				
040-1		682566-8	CORD GUARD 10	1				
041-1		691015-4	POWER SUPPLY CORD 0.75-2-2.5	1				
042		417388-5	REAR COVER	1				
043		911258-5	PAN HEAD SCREW M5X35	2				
A01		782401-1	LOCK NUT WRENCH 20	1				
A02		A-81262	CARBON BRUSH CB-411A	2			65036	

A:9500NB(H)

Interchange
O : Yes
X : No
< : the new part can be substituted for the current.
> : the current part can be substituted for the new.
S : Interchangeable as a set.

