



TH	THAILAND
----	----------

Diagram / Parts List

DGA518

125MM CORDLESS ANGLE GRINDER



(TH) DGA518 / 125MM CORDLESS ANGLE GRINDER

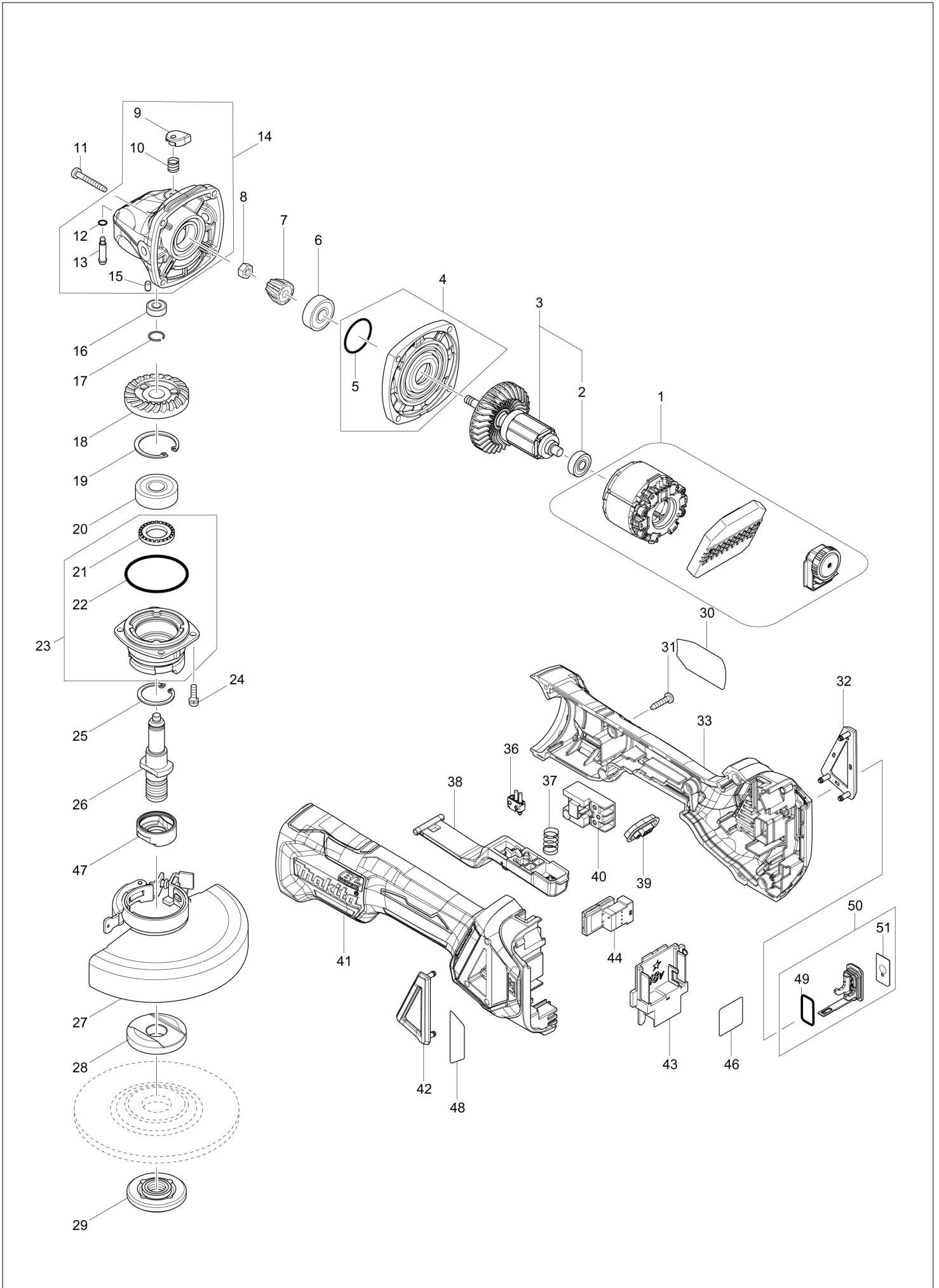

TH	THAILAND
-----------	-----------------

DGA518 / 125MM CORDLESS ANGLE GRINDER

Item	Sub	Parts No.	Parts Description	Qty	I/C	E/C No.	Close No.	Remark
001		629305-5	STATOR COMPLETE	1			DE854	
001-1		629B61-9	STATOR	1	S	DE854		
002		211021-9	BALL BEARING 607LLB	1				
003		510300-5	ROTOR ASS'Y	1			D7193	
	D10		INC. 2				D7193	
003-1		510300-5	ROTOR ASS'Y	1	O	D7193		
	D10		INC. 2			D7193		
004		135930-7	GEAR HOUSING COVER ASSEMBLY	1				
	D10		INC. 5					
005		213445-5	O-RING 26	1				
006		210042-8	BALL BEARING 629LLB	1				
007		227541-3	SPIRAL BEVEL GEAR 10	1			C3594	
007-1		226861-2	SPIRAL BEVEL GEAR 10	1	S	C3594		
008		252186-8	HEX. NUT M6	1				
009		417771-6	PIN CAP	1				
010		233072-2	COMPRESSION SPRING 8	1				
011		266361-0	TAPPING SCREW 4X30	4				
012		213960-9	O RING 5	1				
013		256546-6	SHOULDER PIN 4	1				
014		135929-2	GEAR HOUSING ASSEMBLY	1				
	D10		INC. 9,10,12,13,15					
015		263002-9	RUBBER PIN 4	1				
016		210006-2	BALL BEARING 696ZZ	1				
017		233950-6	RING SPRING 11	1				
018		227641-9	SPIRAL BEVEL GEAR 37	1			C3594	
018-1		226862-0	SPIRAL BEVEL GEAR 37	1	S	C3594		
019		962151-6	RETAINING RING R-32	1				
020		211129-9	BALL BEARING 6201DDW	1				
021		262153-5	FELT RING 16	1				
022		213622-9	O RING 45	1				
023		135949-6	BEARING BOX ASSEMBLY	1				
	D10		INC. 21,22					
024		911121-2	PAN HEAD SCREW M4X14	4				
025		962105-3	RETAINING RING R-26	1				
026		326672-6	SPINDLE	1				
027		123145-8	TOOLLESS WHEELCOVER 125AK ASS'Y	1				
	C10	213009-5	O RING 4	1			DS662	
	C20	265180-1	PAN HEAD SCREW M5X16	1				
028		224447-6	INNER FLANGE 42B	1				
029		224554-5	LOCK NUT 14-45	1				
030		854A02-2	DGA518 NAME PLATTE	1				
031		266326-2	TAPPING SCREW 4X18	5				
032		455450-8	DUST COVER R	1				
033		183H85-0	MOTOR HOUSING SET	1				
	C10	263005-3	RUBBER PIN 6	2				
	D10		INC. 41					
036		632E12-1	SWITCH UNIT	1				
037		234357-9	COMPRESSION SPRING 11	1				
038		142976-6	SWITCH LEVER COMPLETE	1				
039		142901-7	INDICATOR PANEL COMPLETE	1				
040		650734-1	SWITCH TG73BDS-2	1				
041		183H85-0	MOTOR HOUSING SET	1				
	C10	263005-3	RUBBER PIN 6	2				
	D10		INC. 33					
042		455449-3	DUST COVER L	1				
043		643874-2	TERMINAL	1				
044		620752-3	SUB CONTROLLER	1				
046		854A09-8	DGA518 SERIAL NO. LABEL	1				
047		310514-4	LEAD FLANGE	1				
048		816D93-9	INDICATION LABEL	1				
049A		213275-4	O RING 18	1			C2104	
049B		213275-4	O RING 18	1			C2104	
049C		213218-6	O RING 16	1			DA223	
049D		213218-6	O RING 16	1			DA223	
049-1A		213218-6	O RING 16	1	<	C2104	DA223	

A:DGA518ZU(N)
 B:DGA518RTEU(H)
 C:DGA518Z(N)
 D:DGA518RTE(H)

Interchange
 O : Yes
 X : No
 < : the new part can be substituted for the current.
 > : the current part can be substituted for the new.
 S : Interchangeable as a set.

TH	THAILAND
-----------	-----------------

DGA518 / 125MM CORDLESS ANGLE GRINDER

Item	Sub	Parts No.	Parts Description	Qty	I/C	E/C No.	Close No.	Remark
049-1B		213218-6	O RING 16	1	<	C2104	DA223	
049-1C		213A05-9	O-RING16	1	O	DA223		
049-1D		213A05-9	O-RING16	1	O	DA223		
049-2A		213A05-9	O-RING16	1	O	DA223		
049-2B		213A05-9	O-RING16	1	O	DA223		
050A		183H92-3	CAP SET	1			C2104	
	D10		INC. 49,51				C2104	
050B		183H92-3	CAP SET	1			C2104	
	D10		INC. 49,51				C2104	
050C		183J85-2	CAP SET	1			C3942	
050D		183J85-2	CAP SET	1			C3942	
050-1A		183J85-2	CAP SET	1	O	C2104	C3942	
	D10		INC. 49,51			C2104	C3942	
050-1B		183J85-2	CAP SET	1	O	C2104	C3942	
	D10		INC. 49,51			C2104	C3942	
050-1C		140G30-2	CAP COMPLETE	1	<	C3942		
050-1D		140G30-2	CAP COMPLETE	1	<	C3942		
050-2A		140G30-2	CAP COMPLETE	1	<	C3942		
	D10		INC. 49,51			C3942		
050-2B		140G30-2	CAP COMPLETE	1	<	C3942		
	D10		INC. 49,51			C3942		
051		813T75-8	CAP LABEL	1			C3942	
051-1		818H48-4	CAP LABEL	1	<	C3942		
052		620K23-4	CONTROLLER	1	S	DE854		
053		652119-7	PAN HEAD SCREW M2X6	6	S	DE854		
A01		A-80656	GRINDING WHEEL 125 WA36N	1				
A02		158237-4	GRIP 36 COMPLETE	1				
A03		782423-1	LOCK NUT WRENCH 35	1				
A04A		198906-5	WIRELESS UNIT SET	1			Y07602	
A04B		198906-5	WIRELESS UNIT SET	1			Y07602	
A04-1A		199393-1	WIRELESS UNIT SET	1		C3819	D4357	
A04-1B		199393-1	WIRELESS UNIT SET	1		C3819	D4357	
A04-2A		199393-1	WIRELESS UNIT SET	1	<	D4357	DB384	
A04-2B		199393-1	WIRELESS UNIT SET	1	<	D4357	DB384	
A04-3A		199393-1	WIRELESS UNIT SET	1	<	DB384		
A04-3B		199393-1	WIRELESS UNIT SET	1	<	DB384		
A05B		***DC18RC	DC18RC FAST CHARGER	1				
	D10		COMPO-PARTS					
A05D		***DC18RC	DC18RC FAST CHARGER	1				
	D10		COMPO-PARTS					
A06B		197280-8	BATTERY BL1850B SET	2			C2803	
A06D		197280-8	BATTERY BL1850B SET	2			C2803	
A06-1B		199282-0	BATTERY BL1850B SET	2	<	C2803	D0161	
A06-1D		199282-0	BATTERY BL1850B SET	2	<	C2803	D0161	
A06-2B		199282-0	BATTERY BL1850B SET	2	<	D0161		
A06-2D		199282-0	BATTERY BL1850B SET	2	<	D0161		
A07B		450128-8	BATTERY COVER	1				
A07D		450128-8	BATTERY COVER	1				
A08B		821734-0	PLASTIC CASE	1			D1862	
	C10	162315-4	LATCH	2			D1862	
A08D		821734-0	PLASTIC CASE	1			D1862	
	C10	162315-4	LATCH	2			D1862	
A08-1B		821817-6	PLASTIC CASE	1	O	D1862		
	C10	162315-4	LATCH	2		D1862		
A08-1D		821817-6	PLASTIC CASE	1	O	D1862		
	C10	162315-4	LATCH	2		D1862		
F02-1		194514-0	VIBRATION PROOF GRIP SET	1	O	C6582		
F04-1		198416-2	DUST COLLECTING W/C 125CD SET	1	<	B7719		
F23		191W06-8	115/125MM DUST COVER K SET	1		DA627		
	C10	743129-6	BRUSH A	1		Y08890		
	C20	743130-1	BRUSH B	1		Y08890		

A:DGA518ZU(N)
 B:DGA518RTEU(H)
 C:DGA518Z(N)
 D:DGA518RTE(H)

Interchange
 O : Yes
 X : No
 < : the new part can be substituted for the current.
 > : the current part can be substituted for the new.
 S : Interchangeable as a set.