



TH	THAILAND
----	----------

# Diagram / Parts List

**DG002G**

**CORDLESS EARTH AUGER**



(TH) DG002G / CORDLESS EARTH AUGER

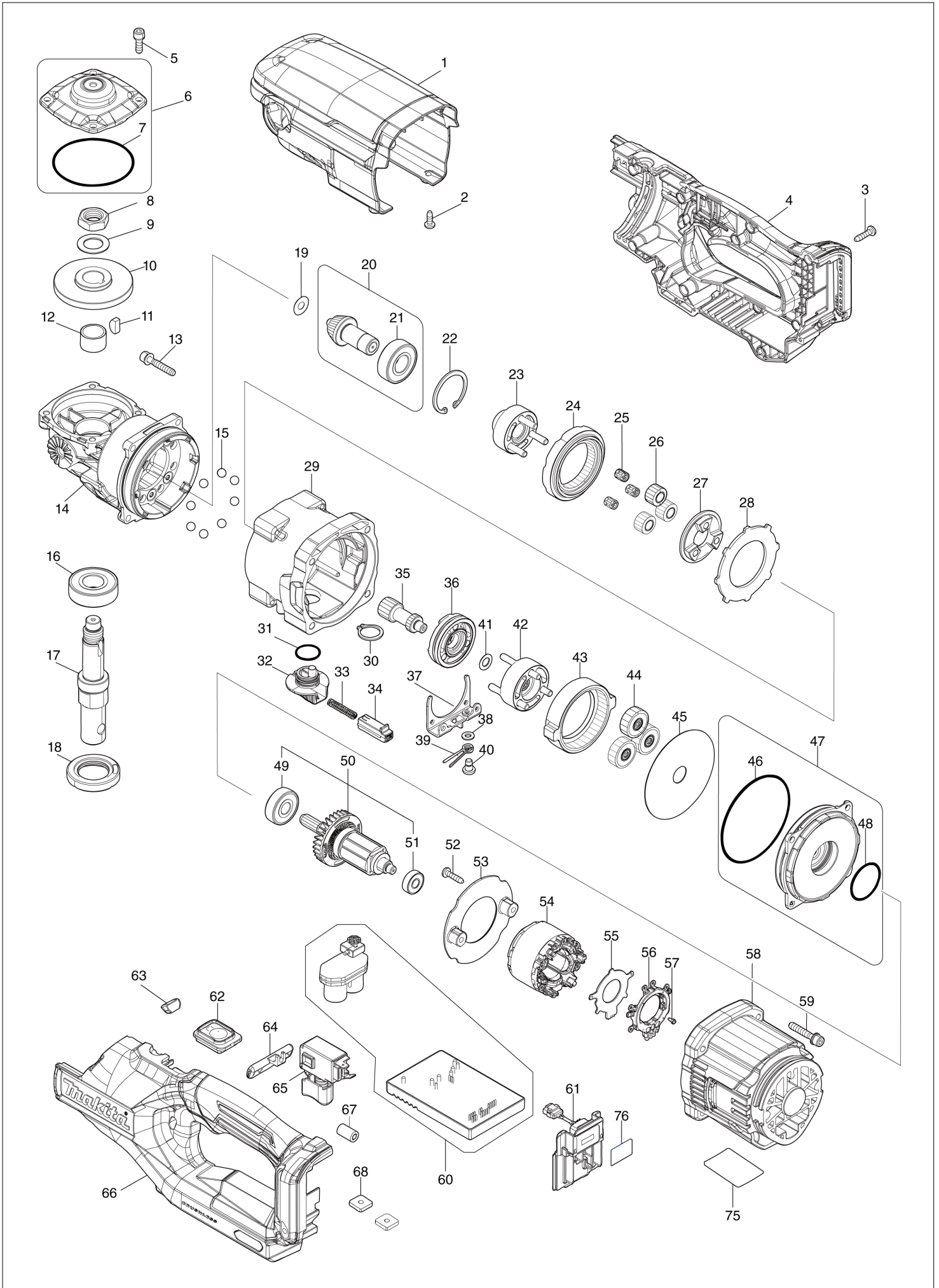

(TH) DG002G / CORDLESS EARTH AUGER

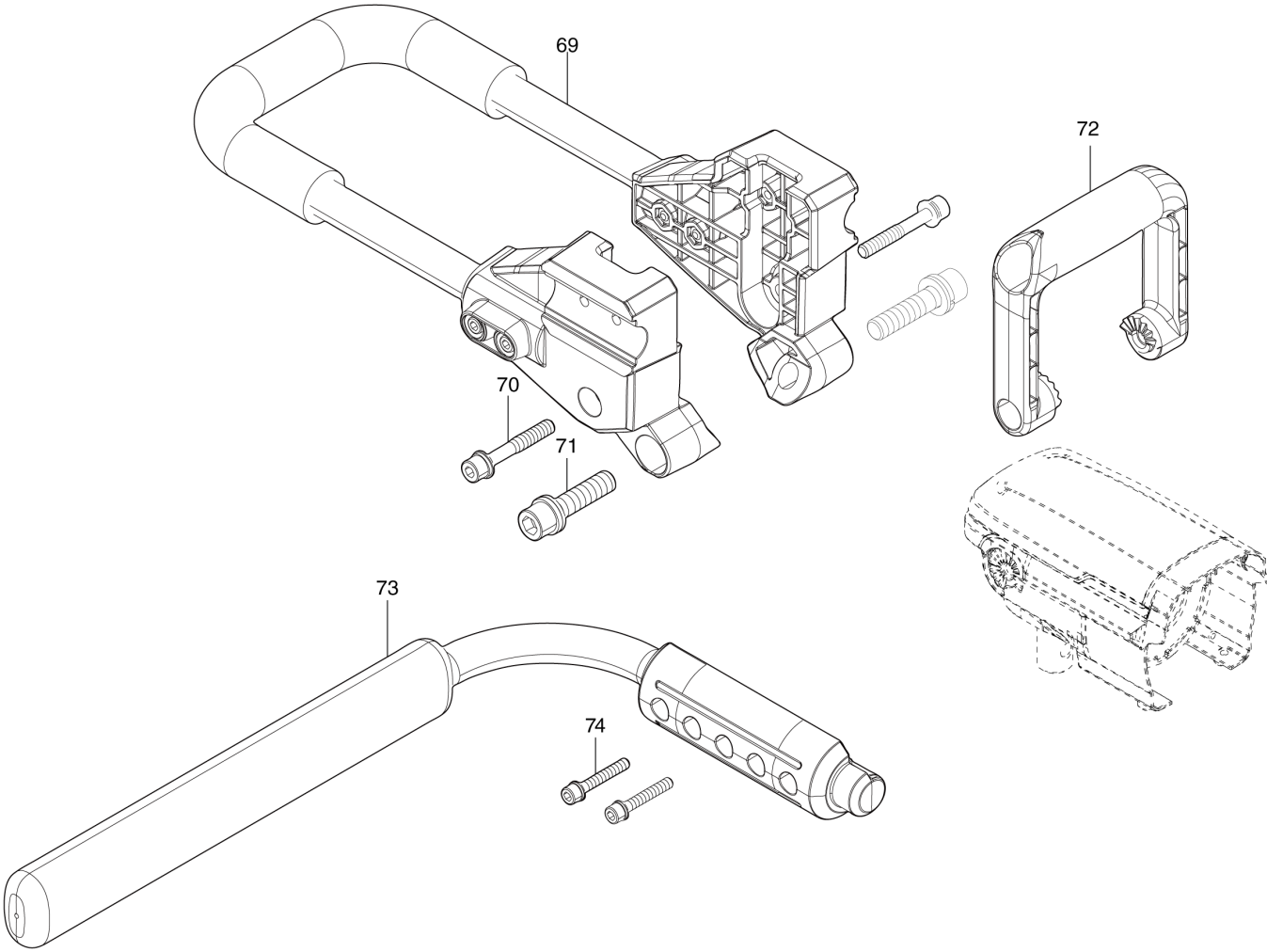

<b>TH</b>	<b>THAILAND</b>
-----------	-----------------

### DG002G / CORDLESS EARTH AUGER

Item	Sub	Parts No.	Parts Description	Qty	I/C	E/C No.	Close No.	Remark
001		458430-3	TOP COVER	1				
002		266026-4	TAPPING SCREW BIND CT 4X12	2				
003		266326-2	TAPPING SCREW 4X18	10				
004		183Y57-7	HANDLE SET	1				
	C10	263005-3	RUBBER PIN 6	2				
	C20	252126-6	HEX. LOCK NUT M4-7	1				
	C30	8012U4-2	XGT LOGO LABEL	1				
	D10		INC. 66					
005		266086-6	HEX. SOCKET HEAD BOLT M5X16	4				
006		140A21-7	GEAR HOUSING COVER COMPLETE	1				
	D10		INC. 7					
007		213709-7	O RING 63	1				
008		252267-8	HEX. NUT M16-22	1				
009		253771-0	FLAT WASHER 16	1				
010		227920-5	SPIRAL BEVEL GEAR 40	1				
011		254032-1	WOODRUFF KEY 5	1				
012		257440-5	SLEEVE 17	1				
013		265695-8	H. S. H. BOLT M5X30 WITH WRM	4			DN095	
013-1		265D24-9	H. S. H. BOLT M5X30 WITH WRM	4	O	DN095		
014		141D39-9	GEAR HOUSING COMPLETE	1				
	C10	213507-9	O RING 40	1				
	C20	213755-0	O RING 75	1				
015		216022-2	STEEL BALL 7.0	8				
016		211278-2	BALL BEARING 6203DDW	1				
017		327C19-5	SPINDLE	1				
018		141S89-4	BEARING RETAINER32-43 COMPLETE	1				
019		253411-0	FLAT WASHER 6	1				
020		136563-1	SPIRAL BEVEL GEAR 13 ASS'Y	1				
	D10		INC. 21					
021		211206-7	BALL BEARING 6202LLB	1				
022		962153-2	RETAINING RING R-35	1				
023		140A13-6	CARRIER A COMPLETE	1				
024		226177-5	INTERNAL GEAR 40	1				
025		212193-3	NEEDLE CAGE 5810	3				
026		226176-7	SPUR GEAR 13	3				
027		223188-1	CAM	1				
028		347365-2	WASHER 65	1				
029		127809-6	GEAR CASE COMPLETE	1				
030		961058-3	RETAINING RING (EXT) S-18	1				
031		213265-7	O RING 17	1				
032		458433-7	CHANGE LEVER	1				
033		233279-0	COMPRESSION SPRING 4	1				
034		458434-5	LOCK BUTTON	1				
035		226175-9	SPUR GEAR 14	1				
036		310876-0	CHANGE RING	1				
037		347366-0	CHANGE GUIDE	1				
038		267010-2	FLAT WASHER 5	1				
039		231657-8	TORSION SPRING 6	1				
040		265628-3	+ BINDING HEAD SCREW M5	1				
041		253215-0	FLAT WASHER 8	1				
042		140A14-4	CARRIER B COMPLETE	1				
043		226174-1	INTERNAL GEAR 71	1				
044		140A12-8	SPUR GEAR 29 COMPLETE	3				
045		253412-8	FLAT WASHER 15	1				
046		213755-0	O RING 75	1				
047		140A20-9	MOTOR BRACKET COMPLETE	1				
	D10		INC. 46,48					
048		213406-5	O RING 30	1				
049		211087-9	BALL BEARING 6200DDW	1				
050		519689-8	ROTOR ASSY	1			DS817	
	D10		INC. 49,51				DS817	
050-1		519689-8	ROTOR ASSY	1	O	DS817		
	D10		INC. 49,51			DS817		
051		211022-7	BALL BEARING 607ZZ	1				
052		266326-2	TAPPING SCREW 4X18	2				

A:DG002GZ(N)  
B:DG002GM101(H)

Interchange  
O : Yes  
X : No  
< : the new part can be substituted for the current.  
> : the current part can be substituted for the new.  
S : Interchangeable as a set.

